

2001NB/2001E Pneumatic & Electric Liquid Level Control, High Pressure No-Bleed Determining the Model Number

Example given: Standard Model 2AS-S R D—Series 2001NB, 2" Screwed Body, Snap Pilot, Right Hand Mounting, with Direct Acting Control.

MODEL 2AS - S R D-VF

- 15AS • 1 1/2" Screwed
 2AS • 2" Screwed
 2AF • 2" Flanged
 3AF • 3" Flanged
 4AF • 4" Flanged
 4AG • 4" Grooved
 4AU • 4" Union
 4AUS • 4" Union w/S.G.
- Note: Consult factory for other options.



- Options — VF • Vertical Displacer*
 C • Chain
 M • Stainless Steel Displacer
- Control Action — D • Direct
 R • Reverse
- Mounting — R • Right Hand
 L • Left Hand
- Pilot — S • Snap
 T • Throttle
 E • Electric SPDT
 ED • Electric DPDT

Additional Information Required

- Body Connection Type: Size and Rating
- Fluid Media
- Fluid Temperatures: Maximum and Minimum
- Displacer Size and Material: Standard is 1 7/8" X 12" PVC; 1 7/8" X 12" Acrylic or Stainless Steel optional.

*Displacer Arm Length: Arm length is figured from center line of control box. 15" Standard on vertical displacer, 12 1/2" Standard on horizontal displacer. (Other lengths available upon application)

Snap-Acting Pilot • No-Bleed Positive On/Off Flow Action

The Snap-Acting Pilot is comprised of two inner valves. Valve (1) admits system supply gas to output. Valve (2) controls system exhaust from output. Valve (1), as shown in the closed position (Fig. 1), is held closed by force exerted from supply gas. When upward flapper bar force transferred to Valve (2) is sufficient enough to overcome supply force, the ball snaps upward, allowing supply pressure to output port, which operates the diaphragm motore valve (not shown nor included with the control). The spherical end of valve (2) closes the exhaust port the instant the ball snaps upward and remains seated against supply pressure until force on the valve diminishes. As force is removed from valve (2), causing it to unseat, a simultaneous action occurs, causing valve (1) to seat instantly, closing the supply port to output and opening output to exhaust, allowing the diaphragm motor valve to reverse its action.

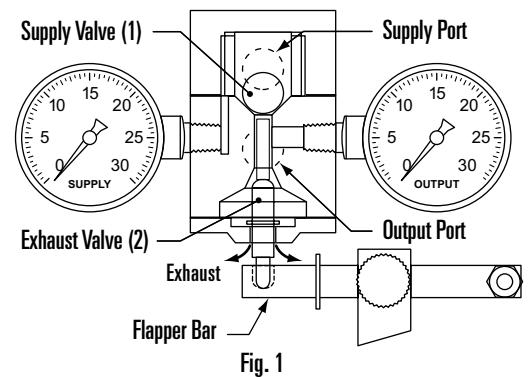

Throttle Pilot • No-Bleed Modulating Flow Action

The Throttle Pilot utilizes a diaphragm, which creates a forced balance pilot (Fig 2). Output pressure acts upon the diaphragm causing it to push back at the same force being applied to the lower seat. More force on the seat produces a proportionate increase in pilot pressure. When the flapper bar of the control exerts upward force on the lower valve seat (3), it forces the lower seat closed against valve body and opens the supply valve (4). (Supply pressure enters the system, increasing until the control and diaphragm motor valve pressure equals the flapper bar force and produces a forced system balance.) The control will stay in this position until a decrease in the tank level reduces the force allowing exhaust, or an increase in the level produces an action as described. System supply gas does not flow while the pilot is in balance.

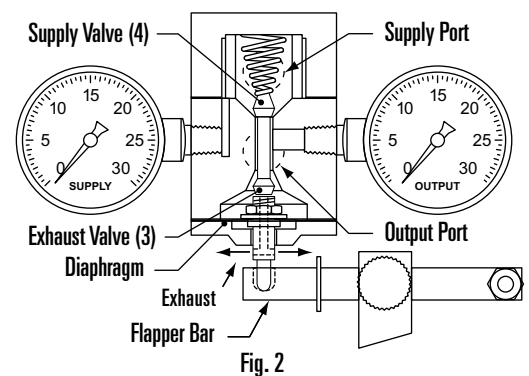

2001NB/2001E Pneumatic & Electric Liquid Level Control, High Pressure No-Bleed

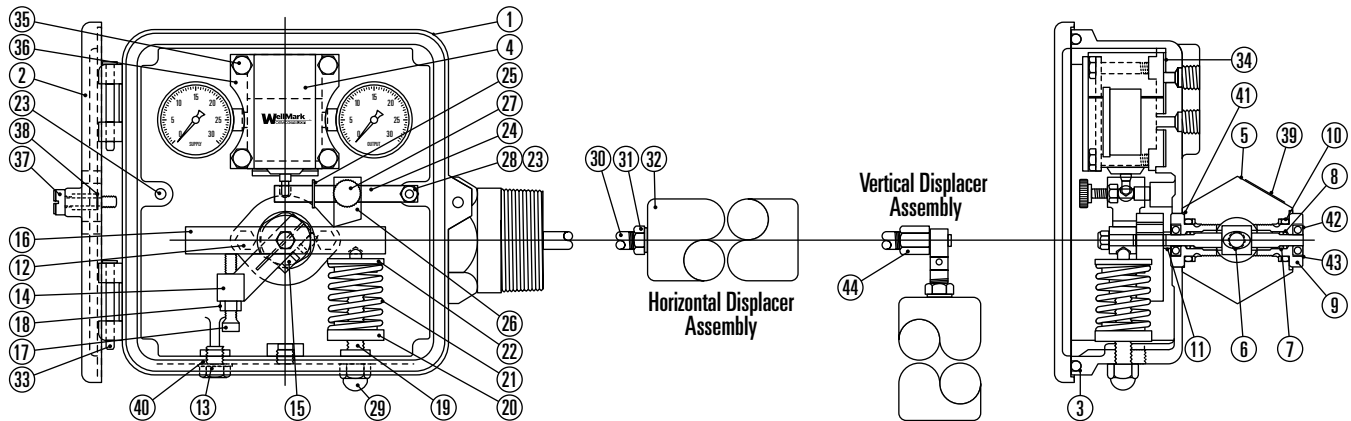

Parts List

Item	Description	Qty.	Part No.
1	CONTROL BOX, DIE CAST ALUMINUM	1	05012-4841
2	COVER, DIE CAST ALUMINUM	1	05012-4834
*3	BOX SEAL, NEOPRENE	1	06000-5097
*4	SNAP PILOT ASSY., ALUMINUM & 316 S.S.	1	06500-5304
	THROTTLE PILOT ASSY., ALUMINUM & 316 S.S.	1	06500-5387
5	BODY, ASTM A-108GR. 1018	1	05011-4560
6	PIVOT SHAFT, ASTM A-276 TY.316	1	05011-4511
*7	O-RING, VITON®	2	05000-0769
*8	BACK UP RING, TEFLON®	2	06000-1179
9	SHAFT RETAINER, ASTM A-276 TY.316	2	05012-9389
*10	O-RING, VITON®	2	05000-1155
11	SPACER, ASTM A-276 TY. 316	1	05011-4495
12	CAP SCREW, 18-8 S.S.	2	05000-5578
13	CAP SCREW, 18-8 S.S.	1	05000-5453
14	ADJUSTING BAR, ALUMINUM	1	05011-4438
15	CAP SCREW, 18-8 S.S.	2	05000-2526
16	TORQUE BAR, ALUMINUM	1	05011-4545
17	ADJ. SCREW, ASTM A-276 TY.316	1	05011-4537
18	JAM NUT, 18-8 S.S.	1	05000-2559
19	STUD, 18-8 S.S.	1	05011-4552
20	LOWER SPRING GUIDE, ALUMINUM	1	05011-4529
21	SPRING, ASTM A-313	1	06000-4157
22	UPPER SPRING GUIDE, ALUMINUM	1	05011-4479
23	STUD, FLAPPER BAR, ASTM A-276 TY.316	2	05012-9371
24	FLAPPER BAR, ASTM A-276 TY.316	1	05011-4404

*Recommended Spare Part

Item	Description	Qty.	Part No.
25	TRU-ARC RING, PH 15-7 MO	1	06000-1385
26	FULCRUM, ALUMINUM	1	05011-4412
27	THUMB SCREW, S.S./PLASTIC	1	06500-5429
28	NY-LOC NUT, STAINLESS STEEL	2	05000-2567
29	ACORN NUT, STAINLESS STEEL	1	05000-2575
30	DISPLACER ARM, STD., ASTM A-276 TY.316	1	06000-1534
	DISPLACER ARM, VF, ASTM A-276 TY.316	1	05011-9296
31	DISPLACER BUSHING, ASTM A-276 TY.316	1	06000-5105
32	DISPLACER, PVC	1	05012-3561
33	HINGE PIN, STEEL PLATED	2	06000-7537
*34	GASKET, NEOPRENE	1	06000-4819
35	CAP SCREW, 18-8 S.S.	4	05000-5313
36	PILOT CLAMP, 304 S.S.	1	05012-6325
37	PANEL SCREW, STAINLESS STEEL	1	06000-1153
38	RETAINER, STAINLESS STEEL	1	06000-2672
39	SERIAL TAG, ALUMINUM	1	06000-1922
*40	THREAD SEAL, STEEL/BUNA N	1	06000-0395
*41	GASKET, VITON®	1	10016
42	BEARING, STAINLESS STEEL	2	06000-7552
43	TOLERANCE RING, STAINLESS STEEL	2	06000-7560
44	ADAPTER V.D. ASSY., ASTM A-276 TY.316	1	06500-4350
45	COVER GLASS, LEXAN (NOT SHOWN)	2	10916
46	COVER GLASS PLATE, S.S. (NOT SHOWN)	2	10915
47	COVER GLASS GASKET, NEOPRENE (NOT SHOWN)	2	10917
48	SCREW, PLATED STEEL (NOT SHOWN)	8	001501P

Repair Kits

BAR FLAPPER KIT	1	03500-1882
NUT	1	05000-2567
RETAINER RING	1	06000-1385
FLAPPER BAR	1	05011-4404
CLAMP KIT	1	03500-1890
CAP SCREW	4	05000-5313
CLAMP	1	05012-6325
SHAFT RETAINER KIT	1	06500-5601
SHAFT RETAINER	1	05012-9389
BEARING	1	06000-7552
TOLERANCE RING	1	06000-7560
STD. FULCRUM KIT	1	03500-1898
FULCRUM	1	05011-4412
THUMB SCREW	1	06500-5429
BAR ADJUSTING LEVEL KIT	1	03500-1906
BAR ADJUSTING LEVEL	1	05011-4438
JAM NUT	1	05000-2559
CAP SCREW	2	05000-2526
ADJUSTING SCREW	1	05011-4537

TORQUE BAR KIT	1	03500-1914
STD. TORQUE BAR	1	05011-4545
LOCK NUT	1	05000-2567
SENSITIVITY SCALE	1	10739
SNAP PILOT KIT	1	03500-1114
FILTER	1	06000-1526
GASKET	1	06000-1484
PIN W/RETAINER RING	1	05011-4503
	1	06000-1393
BALL	1	06000-1906
THROTTLE PILOT KIT	1	03500-1163
FILTER	1	06000-1526
GASKET	1	06000-1484
DIAPHRAGM	1	06000-1559
SEAT	1	05011-4594
FLAT WASHER-NYLON	1	05011-4602
JAM NUT	1	05000-2559
PEANUT	1	05011-4586
SPRING	1	06000-1567

Model and Part Numbers

Model No.	Displacer Orientation	Part No.
2AS-SLD-A	HORIZONTAL-STANDARD	03051-0850
2AS-SRD-A	HORIZONTAL-STANDARD	03051-0800
2AS-TLD	HORIZONTAL-STANDARD	03051-0892
2AS-TRD	HORIZONTAL-STANDARD	03051-0918
2AS-SLD-VF	VERTICAL DISPLACER	03051-0868
2AS-SRD-VF	VERTICAL DISPLACER	03051-0876
2AS-TLD-VF	VERTICAL DISPLACER	03051-0900
2AS-TRD-VF	VERTICAL DISPLACER	03051-0926

Charts indicate the Kit and Part Descriptions, the Quantities required and the Part Number for ordering.

2001NB/2001E Pneumatic & Electric Liquid Level Control, High Pressure No-Bleed

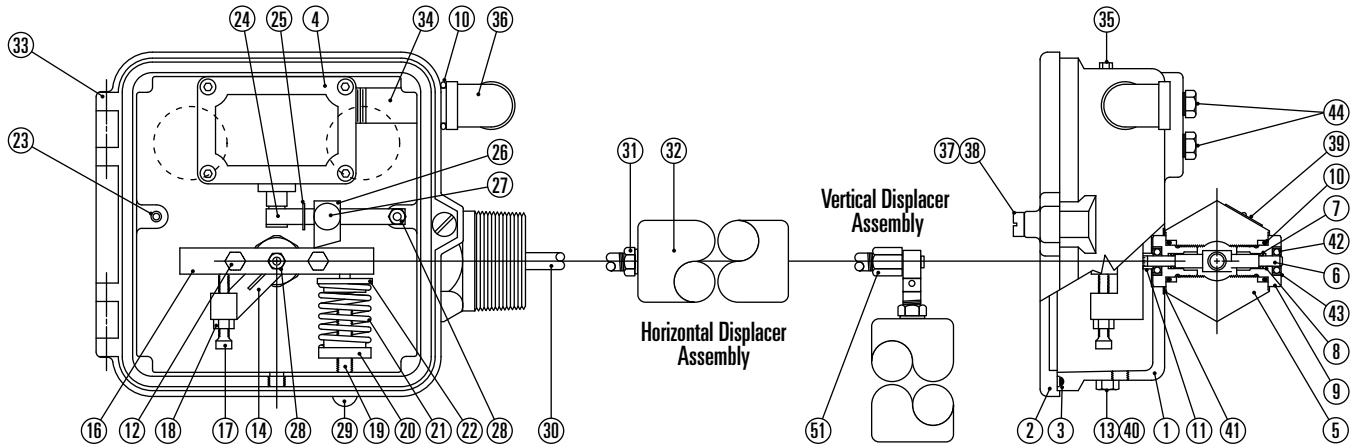

Parts List

Item	Description	Qty.	Part No.
1	CONTROL BOX, DIE CAST ALUMINUM	1	05012-4843
2	COVER, DIE CAST ALUMINUM	1	05012-4834
*3	BOX SEAL, NEOPRENE	1	06000-5097
4	SWITCH	1	10006
5	BODY, ASTM A-108GR. 1018	1	05011-4560
6	PIVOT SHAFT, ASTM A-276 TY.316	1	05011-4511
*7	O-RING, VITON®	2	05000-0769
*8	BACK UP RING, TEFLON®	2	11087
9	SHAFT RETAINER, ASTM A-276 TY.316	2	05012-9398
*10	O-RING, VITON®	3	05000-1155
11	SPACER, ASTM A-276 TY. 316	1	05011-4495
12	CAP SCREW, 18-8 S.S.	2	05000-5578
13	CAP SCREW, 18-8 S.S.	1	05000-5453
14	ADJUSTING BAR, ALUMINUM	1	05011-4438
15	CAP SCREW, 18-8 S.S. (NOT SHOWN)	2	05000-2526
16	TORQUE BAR, ALUMINUM	1	05011-4545
17	ADJ. SCREW, ASTM A-276 TY.316	1	05011-4537
18	JAM NUT, 18-8 S.S.	1	05000-2559
19	STUD, 18-8 S.S.	1	05011-4552
20	LOWER SPRING GUIDE, ALUMINUM	1	05011-4529
21	SPRING, ASTM A-313	1	06000-4157
22	UPPER SPRING GUIDE, ALUMINUM	1	05011-4479
23	STUD, FLAPPER BAR, ASTM A-276 TY.316	2	05012-9371
24	FLAPPER BAR, ASTM A-276 TY.316	1	06500-7233
25	TRU-ARC RING, PH 15-7 MO	1	06000-1385

Item	Description	Qty.	Part No.
26	FULCRUM, ALUMINUM	1	05011-4412
27	THUMB SCREW, S.S./PLASTIC	1	06500-5429
28	NY-LOC NUT, STAINLESS STEEL	2	05000-2567
29	ACORN NUT, STAINLESS STEEL	1	05000-2575
30	FLOAT ARM, ASTM A-276 TY.316	1	06000-1534
31	FLOAT BUSHING, ASTM A-276 TY.316	1	06000-5105
32	DISPLACER, PVC	1	05012-3561
33	HINGE PIN, STEEL PLATED	2	06000-7537
*34	PIPE NIPPLE	1	06000-8386
35	CAP SCREW, 18-8 S.S.	2	05000-1586
36	ELBOW	1	06000-8394
37	PANEL SCREW, STAINLESS STEEL	1	06000-1153
38	PANEL SCREW RETAINER, STAINLESS STEEL	1	06000-2672
39	SERIAL TAG, ALUMINUM	1	06000-1922
*40	THREAD SEAL, STEEL/BUNA N	1	06000-0395
*41	GASKET	1	10016
42	BEARING, STAINLESS STEEL	2	06000-7552
43	TOLERANCE RING, STAINLESS STEEL	2	06000-7560
44	PLUG	2	10149
45	COVER GLASS, LEXAN (NOT SHOWN)	2	10916
46	COVER GLASS PLATE, S.S. (NOT SHOWN)	2	10915
47	COVER GLASS GASKET, NEOPRENE (NOT SHOWN)	2	10917
48	COVER SCREW, PLATED STEEL (NOT SHOWN)	8	001501-P
51	ADAPTER V.D. ASSY., ASTM A-276 TY.316	1	06500-4350

*Recommended Spare Part

Repair Kits

BAR FLAPPER KIT	1	03500-1882
NUT	1	05000-2567
RETAINER RING	1	06000-1385
FLAPPER BAR	1	05011-4404
CLAMP KIT	1	03500-1890
CAP SCREW	4	05000-5313
CLAMP	1	05012-6325
SHAFT RETAINER KIT	1	06500-5601
SHAFT RETAINER	1	05012-9389
BEARING	1	06000-7552
TOLERANCE RING	1	06000-7560

TORQUE BAR KIT	1	03500-1914
STD. TORQUE BAR	1	05011-4545
LOCK NUT	1	05000-2567
SENSITIVITY SCALE	1	10739
STD. FULCRUM KIT	1	03500-1898
FULCRUM	1	05011-4412
THUMB SCREW	1	06500-5429
BAR ADJUSTING LEVEL KIT	1	03500-1906
BAR ADJUSTING LEVEL	1	05011-4438
JAM NUT	1	05000-2559
CAP SCREW	2	05000-2526
ADJUSTING SCREW	1	05011-4537

Charts indicate the Kit and Part Descriptions, the Quantities required and the Part Number for ordering.

Switch Specifications

Electric Switch Explosion Proof
 Electric Switch, Single Pole / Double Throw, UL and CSA listed:
 "L96" 15 amps, 125, 250, or 480 VAC; 1/8 HP-125 VAC,
 1/4 HP-250 VAC, 1/2 amp-125 VDC, 1/4 amp-250 VDC

Model and Part Number

Model No.	Displacer Orientation	Part No.
2AS-ERD	HORIZONTAL-STANDARD	03051-9000