

## Installation & Maintenance Instructions for 1" & 2" Series 9500 Safety Relief Valves



### WARNING!

**WellMark Series 9500 relief valves are intended for gaseous application only and are not intended for liquid service. Over-pressure of this relief valve or installation of the relief valve in applications which may see pressure levels beyond those for which the valve is designed may result in leakage and/or catastrophic failure. This failure could result in leaking gas/liquid, damage to surrounding equipment, personal injury or death. To prevent such damage/injury the valve should be installed in a safe location and should be chosen based upon the user's specific application.**

### Application

This valve is intended for general purpose gas and air service, and is recommended for over-pressure protection on separators, compressors, pressure vessels, heater-treaters, gathering and transmission lines, meter runs and other systems where the rated capacities of the valve are commensurate with the requirements of the system. The valve is manufactured in accordance with the ASME Boiler and Pressure Vessel Code and has been capacity tested and certified by the National Board to meet the requirements of Section VIII of the ASME Code, as signified accordingly by the symbols "UV" and "NB" on their nameplates.

### Installation

WellMark safety relief valves should always be installed on a vessel or pipeline in the vertical position with the outlet pointing in a horizontal direction. It is recommended that the system which is being fitted with a safety relief valve be cleaned prior to installation, as construction materials, welding slag and/or Teflon tape are items that commonly cause seating problems.

Relief valves should be installed using the guidelines published by the ASME Section VIII of the Boiler and Pressure Vessel Code, paragraph UG-135:

(a) Safety, safety relief and pilot operated pressure relief valves, and non-reclosing pressure relief devices shall be connected to the vessel in the vapor space above any contained liquid or to piping connected to the vapor space in the vessel which is to be protected.

(b) The opening through all pipe and fittings between a pressure vessel and its pressure relieving device shall have at least the area of the pressure relieving device inlet, and the flow characteristics of this upstream system shall be such that the pressure drop will not reduce the relieving capacity below that required or adversely affect the proper operation of the pressure relieving device. The opening in the vessel wall shall be designed to provide direct and unobstructed flow between the vessel and its pressure relieving device. (See Appendix M.)

(c) When two or more required pressure relieving devices are placed on one connection, the inlet internal cross-sectional area of this connection shall be either sized to avoid restriction flow to the pressure relief devices or made at least equal to the combined inlet areas of the safety devices connected to it. The flow characteristic of the upstream system shall satisfy the requirements of (b) above. (See Appendix M.)

(d) Liquid relief valves shall be connected below the normal liquid level.

(e) There shall be no intervening stop valves between the vessel and its protective device or devices, or between the protective device or devices and the point of discharge, except:

1. when these stop valves are so constructed or positively controlled that the closing of the maximum number of block valves possible at one time will not reduce the pressure relieving capacity provided by the unaffected relieving devices below the required relieving capacity; or

2. under conditions set forth in Appendix M.

(f) The safety devices on all vessels shall be so installed that their proper functioning will not be hindered by the nature of the vessel's contents.

(g) Discharge lines from pressure relieving safety devices shall be designed to facilitate drainage or shall be fitted with drains to prevent liquid from lodging in the discharge side of the safety device, and such line shall lead to a safe place of discharge. The size of the discharge lines shall be such that any pressure that may exist or develop will not reduce the relieving capacity of the relieving devices below that required to properly protect the vessel. [See UG-136 (a)(8) and Appendix M.]

### INLET

Any relief valve affixed to a vessel or pipeline should be done so as to minimize the amount of piping between the vessel or pipeline and the relief valve. Furthermore, any piping used must be equal to or larger than the inlet pipe size of the relief valve. Reduction could cause serious problems in the performance of the valve as it is intended, resulting in a catastrophic disaster.

## OUTLET

Outlet piping from the relief valve should never be more than four feet in length. Pipe used is never to be of a size smaller than the outlet size. Doing so may result in a reduction of the valves designed flow capacity, resulting in serious danger to life and equipment.

## WARNING!

If outlet piping is installed outdoors care must be taken to assure that liquids, if present, cannot form an ice blockage in the piping or valve body. Ice blockage can inhibit the valves ability to perform properly and may result in serious damage or injury. Discharge lines must have protective caps or drains to prevent any liquid from collecting in the valve body or outlet piping. Care should be exercised to assure that any caps used do not cause any kind of back pressure on the relief valve.

## Maintenance

ASME Coded safety relief valves such as the WellMark Series 9500 are manufactured in accordance with the ASME Boiler and Pressure Vessel Code and have been capacity tested and certified by The National Board, to meet the requirements of Section VIII of the ASME Code, as signified accordingly by the symbols "UV" and "NB" on their nameplates. As such, these valves are factory set using calibrated test equipment to achieve the set pressure tolerances required by ASME Code. These tolerances are within 3% of the stamped set pressure. After factory setting, these valves are capped and lead wire sealed.

It is recommended that any maintenance work required be performed by a commercial valve repair shop having a "VR" stamp issued by The National Board of Boiler and Pressure Vessel Inspectors of Columbus, Ohio. The Seat (3) and Blow Down Ring (5) are the most common areas of concern. These components should be inspected annually. Parts manufactured by WellMark must be used for any and all repair of WellMark valves. The pressure setting of any relief valve should never be reset by more than 10% of the original stamped set pressure. It is imperative that any new set pressure be marked on a new tag applied to the valve by the valve repair company.

## Relieving Capacity Formula Slope Method

Given certain information as follows, Safety Relief Valves may be sized by use of various formulas prescribed by Appendix 11, Section VIII, Division I of the ASME Boiler and Pressure Vessel Code for capacities of orifices.

Valve Size	Bore	KA	90% KA	Slope *	90% Slope
1"	.500	.146	.131	2.68	2.41
2"	.850	.458	.412	8.41	7.57

\* ASME certified slopes determined by actual tests conducted at the National Board Testing Laboratory, Columbus, Ohio. NOTE: When sizing for code application use 90% KA or 90% Slope.

$$Q_{(SCFM)} = \text{Pressure Setting times 1.1 plus atmospheric pressure (14.7 psia) times 90% slope.}$$

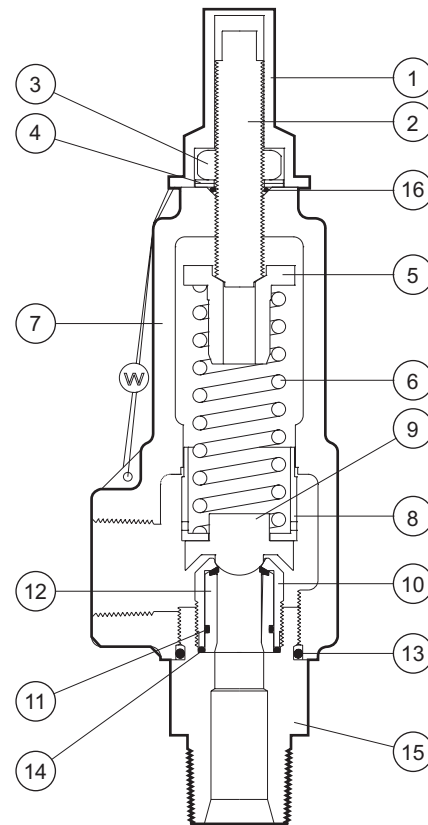

## Parts List

Item	Description	Qty.	1"	2"
1	Cap - Plastic	1	10175	10196
2	Adjustment Screw - Plated Steel	1	10173	20339
3	Lock Nut - Plated Steel	1	10174	10141
4	Seal Washer - Steel/Buna-N	1	10578	10594
5	Spring Guide - Steel	1	20745	20751
	Spring Guide for 2" 1500, 1800 - Steel	1	---	20798
6	1" Spring - SS 3-25 psi	4	10307	---
	1" Spring - SS 25-200 psi	1	10308	---
	1" Spring - SS 200-400 psi	1	10309	---
	1" Spring - SS 400-600 psi	1	10310	---
	1" Spring - SS 600-800 psi	1	10311	---
	1" Spring - SS 800-1200 psi	1	10312	---
	1" Spring - SS 1200-1600 psi	1	10314	---
	1" Spring - SS 1600-2000 psi	1	10316	---
6	2" Spring - SS 3-30 psi	1	---	10296
	2" Spring - SS 30-150 psi	1	---	10297
	2" Spring - SS 150-400 psi	1	---	10298
	2" Spring - SS 400-600 psi	1	---	10299
	2" Spring - SS 600-900 psi	1	---	10301
	2" Spring - SS 900-1200 psi	1	---	10304
	2" Spring - SS 1200-1500 psi	1	---	10797
	2" Spring - SS 1500-1800 psi	1	---	10798
7	Bonnet - Cast Steel	1	30153	30449
8	Disc Guide - SS	1	20746	20752
9	Plug Disc - SS	1	20747R	20753
	Plug Disc for 2" 1500-1800 - SS	1	---	20799
10	Shell, Soft Seat - SS	1	20748R	30754
11	O-Ring - Viton®	1	10696	05000-0983
12	Cylinder, Soft Seat - SS/Viton-70 Duro	1	20749R	20755A
13	O-Ring - Viton®	1	10404	10381
14	O-Ring - Viton®	1	10403	10380
15	Seat Frame, Steel (1" NPT & 2"NPT)	1	20750	20756
16	O-Ring - Viton®	1	10402	10379