

Installation, Operation & Maintenance Instructions for Series 7400 Snaptrol Liquid Level Control with Pneumatic Switch Option

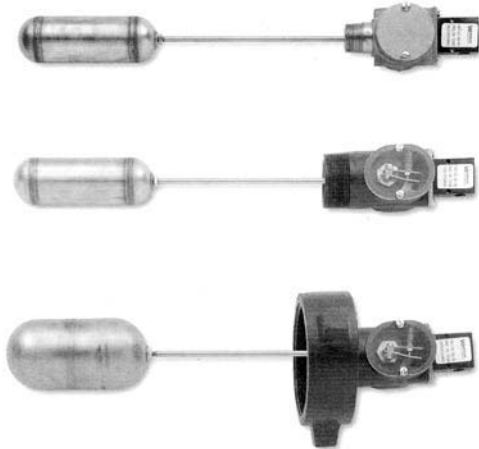

Note: This document may be used in conjunction with WellMark Document, Section No. 3.3, "Series 7400 Snaptrol / LLC, Liquid Level Control, Low Pressure No-Bleed", pages 7 and 8.

WARNING!

Over-pressure of this control or installation of the control in applications which may see pressure levels beyond those for which the control is designed may result in leakage and/or catastrophic failure. This failure could result in leaking liquid or gas, damage to surrounding equipment, personal injury or death. To prevent such damage/injury the control should be installed in a safe location and should be chosen based upon the user's specific application.

It is highly recommended that suitable pressure-relieving devices, as recommended by appropriate codes or standards, be installed in your system to assure that maximum rated pressures are not exceeded.

Installation

The control should be installed on properly configured pipe or fittings with suitable thread sealant or anti-seize compound. Do not over-tighten. Supply connections are 1/4" NPT.

Direct Acting Mode

Install unit with the spring on the topside. This can be accomplished by observing the spring orientation while looking through the Lexan cover plate. Connect supply pressure via tubing to the topside of the microswitch (see diagram). The output tubing is installed on the end connection with the exhaust through the bottom port.

Indirect Acting Mode

Install unit with the spring on the bottom side. Connect supply pressure via tubing to the bottom of the microswitch (see diagram). The output tubing is installed on the end connection with the exhaust through the top port.

CAUTION: Supply pressure should not exceed 75psi.

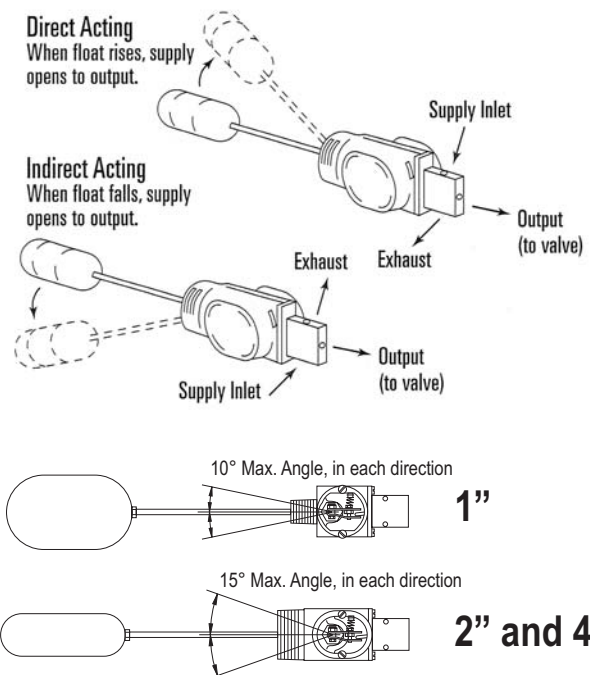

Operation

As liquid in vessel rises the float and arm will also rise, causing the microswitch to trigger, redirecting supply pressure to signal as oriented above. As the liquid level drops the float likewise drops, allowing the microswitch to return to the static position.

Maintenance

The Series 7400 Liquid Level Control requires no routine maintenance. However, as with all instrumentation clean supply is critical to long problem-free operation. An upstream-installed and maintained filter is highly recommended.