

Operation

The 2001NB Level Control utilizes a balanced method, whereby a spring acting on a lever balances the weight of the displacer in the vessel. As liquid rises in the vessel, force is made available via the Torque Bar (16) and Fulcrum (26), to the pilot proportional to the weight of the displaced liquid. As the liquid level rises the amount of force increases to the pilot.

Direct-Acting configuration, whereby rising level **increases** Pilot output. When the unit is configured for Direct-Acting operation the Fulcrum will be located either left or right of the pivot depending upon whether the unit is Left Hand Mount or Right Hand Mount as illustrated below.

LEFT HAND MOUNT

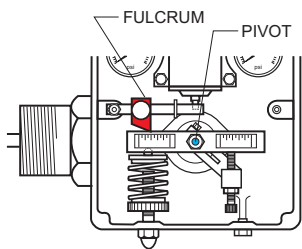

RIGHT HAND MOUNT

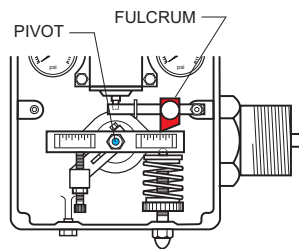

DIRECT-ACTING

Rising level **INCREASES** Pilot output

Reverse-Acting configuration (rising level **decreases** Pilot output) can be accomplished by moving the Fulcrum to the opposite side as shown below.

LEFT HAND MOUNT

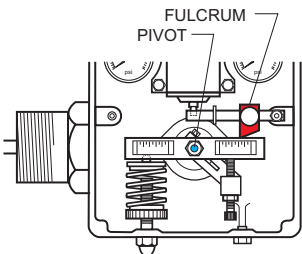

RIGHT HAND MOUNT

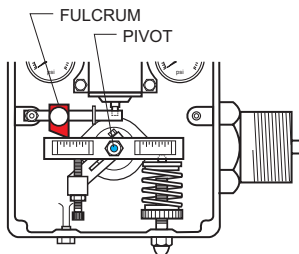

REVERSE-ACTING

Rising level **DECREASES** Pilot output

Span or Dump Span refers to the differential between ON and OFF. This is determined by the position of the Fulcrum along the Torque Bar.

Proportional Band, when referring to a throttling control, is the ratio of displacer actually used as compared to the overall length of the displacer. For instance, a 50% proportional band would utilize 6" of a 12" displacer to achieve a 3-to-15 psi output.

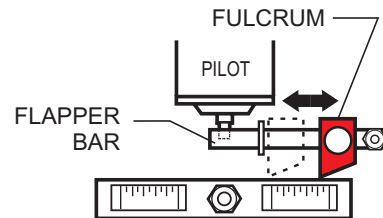

The Dump Span and Proportional Band are adjusted by moving the Fulcrum along the Flapper Bar as necessary to achieve the desired result.

Level Adjustment - The Displacer's weight is held in balance by the Spring (21). Since the Displacer is buoyant, as the level rises the apparent weight or *mass* of the Displacer decreases. As a result of

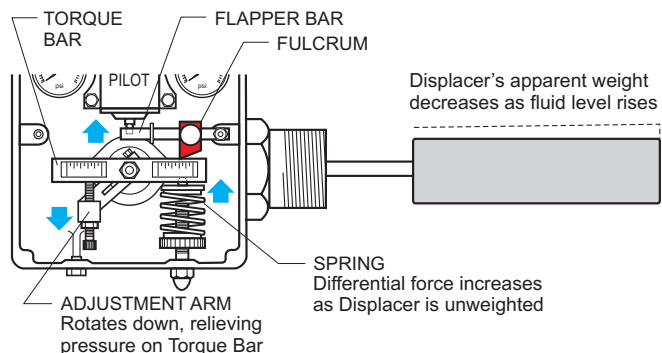

the rising Displacer the Adjusting Bar rotates, relieving pressure on the Torque Bar. This results in an increase in differential Spring force, transmitting that force to the Pilot poppet via the Fulcrum and Flapper Bar. Increasing tension on the Spring lowers the sensed level. Conversely, decreasing the spring force raises the sensed level.

Interface Operation

Some systems require control at the interface distinction between the hydrocarbon and water. This is referred to as *interface operation*. It is possible to adjust the Spring to a point at which the hydrocarbon liquid completely envelopes the displacer without transmitting enough force to engage the pilot and produce any output.

Water has a higher specific gravity than hydrocarbon and naturally separates lower, with hydrocarbon liquid rising above it. When properly adjusted, water can rise to a level on the displacer, changing its apparent weight and causing enough force to engage the pilot, which will then result in output. The 2001NB unit's broad range of control allows liquid interface sensing.

Pilot Operation

Snap-Acting Pilot • No-Bleed On/Off Flow Action

The Snap-Acting Pilot is comprised of two inner valves. Valve (1) admits system supply gas to output. Valve (2) controls system exhaust from output. Valve (1), as shown in the closed position (Fig. 1), is held closed by force exerted from supply gas. When upward Flapper Bar forces pressure transferred to Valve (2) is sufficient enough to overcome supply force, the ball snaps upward, allowing supply pressure to communicate to output port, which operates the diaphragm motor valve (not shown). The spherical end of Valve (2) closes the exhaust port the instant the ball snaps upward and remains seated against supply pressure until force on the valve diminishes. As force is removed from Valve (2), causing it to unseat, a simultaneous action occurs, causing Valve (1) to seat instantly, closing the supply port to output and opening output to exhaust, thereby allowing the diaphragm motor valve to reverse it's action.

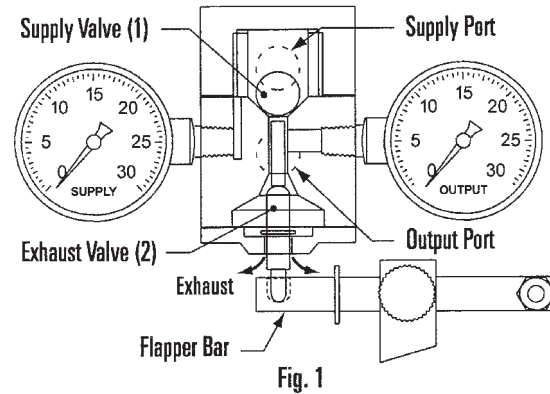

Throttle Pilot • No-Bleed Modulating Flow Action

The Throttle Pilot utilizes a diaphragm, which creates a forced balance Pilot (Fig. 2). Output pressure acts upon the diaphragm causing it to push back at the same force being applied to the lower seat. More force on the seat produces a proportionate increase in Pilot pressure. When the Flapper Bar of the control exerts upward force on the lower valve seat, it forces the lower seat closed against valve body and opens the supply valve. Supply pressure enters the system, increasing until the control and diaphragm motor valve (not shown) pressure equals the Flapper Bar force and produces a forced system balance. The control will stay in this position until a decrease in the tank level reduces the force allowing exhaust, or an increase in the level produces an action as described. System supply gas does not flow while the Pilot is in balance.

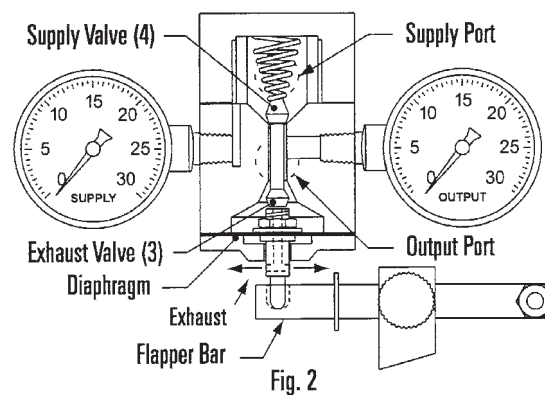

IMPORTANT!

Although the 2001NB Level Control is appropriately referred to as “No-Bleed”, all pneumatic systems require that the diaphragm operated motor valve exhausts or vents pressure off the diaphragm once the valve has completed its actuation cycle. This vented gas, along with the gas within the lines leading from the control to the valve will vent back through the control. This clear distinction, between “bleed” gas and “vent” gas must be made and understood. As with any no- or low-bleed control, the intent is to stop the unnecessary bleed of gas between valve actuation cycles. The 2001NB Level Control will accomplish this task. It will not however, nor will any other no- or low-bleed device stop the required venting of gas from the diaphragm and lines once the valve has cycled.

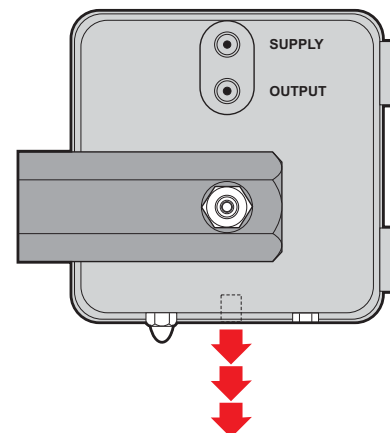

CAUTION!

The 2001NB Level Control has a sealed box which allows the user to pipe vent gas away from the facility as needed. This is highly recommended if the control is to be mounted inside an enclosure that might result in a dangerous build up of gas. Failure to do so may result in damage to equipment, personal injury or death.

Startup

Assure free-travel of the Displacer and Displacer Arm by rocking the Torque Bar by hand and observing corresponding movement of Displacer. The Displacer Arm should be centered in the vessel nozzle to assure that the vessel nozzle does not inhibit free operation. Displacer Arm should be parallel to the ground at installation.

LEVEL ADJUSTMENT

The controller is factory-set for average level and sensitivity.

To DECREASE LEVEL - Increase the compression of the Spring by turning the Adjustment Wheel to the **RIGHT**.

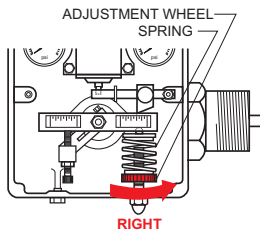

DECREASE LEVEL
by increasing Spring compression

To INCREASE LEVEL - Decrease Spring compression by turning the Adjusting Wheel to the **LEFT**.

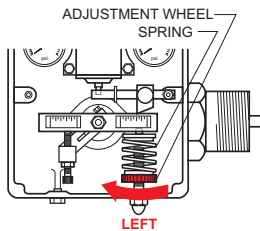

INCREASE LEVEL
by decreasing Spring compression

ADJUSTING PROPORTIONAL BAND (SPAN)

Loosen Thumbscrew on Fulcrum and position the Fulcrum along the Flapper Bar.

To DECREASE BAND (Increase Sensitivity)

Slide Fulcrum along Flapper Bar toward Snap Ring.

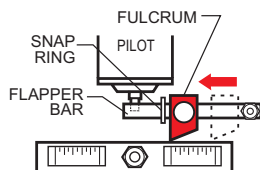

To INCREASE BAND (decrease Sensitivity)

Slide Fulcrum along Flapper Bar away from Snap Ring.

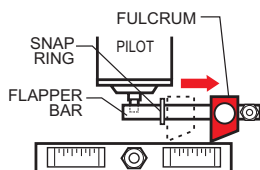

Once desired band/span is achieved re-tighten Thumbscrew.

SETTING INTERFACE LEVEL

The controller is factory-set for average level and sensitivity.

1. Set Fulcrum approx. 1/2" from pivot pin.

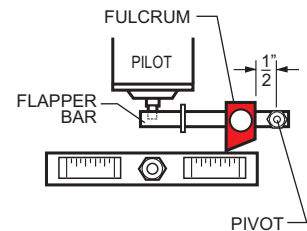

Reduce Spring tension slowly by turning the Adjusting Wheel to the **LEFT**. Allow the upper fluid to rise until it completely submerges the Displacer.

Next, fine-tune the adjustment by turning the Adjusting Wheel to the **RIGHT** until an output signal is attained.

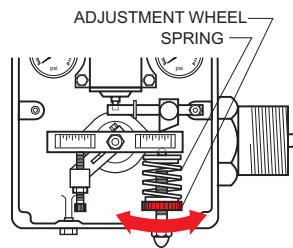

Finally, turn the Adjusting Wheel back to the **LEFT** until the output signal returns to **ZERO**.

2. Allow the lower liquid to rise until the desired interface level is attained.

Fine tune by slowly turning the Adjusting Wheel to the **RIGHT** until an output signal is obtained.

Finally, slowly turn the Adjusting Wheel to the **LEFT** until the output signal returns to **ZERO**.

3. To obtain a shorter dump span, slide the Fulcrum away from the pivot and repeat the above procedure.

Maintenance

WARNING!

Prior to maintenance of the 2001NB Level Control system must be isolated from pressure. Failure to do so may result in personal injury, environmental spill concerns and/or damage to equipment.

The 2001NB Level Control is designed to provide years of reliable service. However, build up of debris, paraffin, etc inside the controller Body can interfere with proper functioning. A regular maintenance program should include checking for this condition.

Maintenance - continued

General Disassembly

Note: This procedure does not include removal or servicing of the Pilot. Refer to section elsewhere on this page for information specific to removal of Pilot. Also, for reference see Sectional Diagram and Parts List on Page 6.

Relax compression on Spring (21) and remove along with the Upper Guide (22). Remove the Stud (19) and Adjustment Wheel (20).

Remove Nyloc Nut (28) from Stud (23) and slide the Flapper Bar (24) off Stud. **DO NOT REMOVE THE STUD**, as it is press-fit into the Control Box. Fulcrum (26) and Thumbscrew (27) should remain in place on the Flapper Bar.

Remove a second Nyloc Nut (28) from the Pivot Shaft (6) and slide Torque Bar off the Pivot Shaft (6).

Hold the Adjusting Bar (14) while loosening two Capscrews (15). Once Adjusting Bar is loose, remove it along with the Adjusting Screw (17) from the Pivot Shaft. The Adjusting Screw need not be removed from the Adjusting Bar. Slide the Spacer (11) from the Pivot Shaft.

Remove two Capscrews (12) holding the Control Box (1) to the Body (5) and disassemble Control Box from Body.

General Reassembly

Mount the Control Box to the Body using the two Capscrews. Screws should be tightened to 6 ft-lbs.

Install the Spacer on the Pivot Shaft.

If the Adjusting Screw was removed from the Adjusting Bar during disassembly it should be refitted, threading it into the Adjusting Bar until an equal amount of threads is showing above and below the Adjusting Bar.

Slide the Adjusting Bar onto the Pivot Shaft, against the Spacer, such that the portion through which the Adjustment Screw is installed is on the opposite side from the Body (see below).

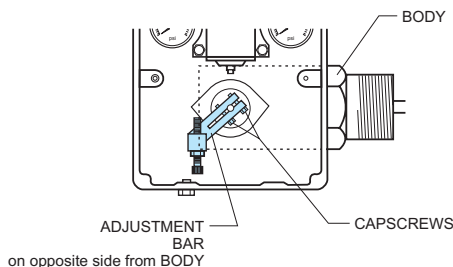

Snug, but **do not tighten** the two Capscrews that hold the Adjusting Bar to the Pivot Shaft.

Temporarily install the Torque Bar onto the Pivot Shaft. Position the Level Adjusting Bar and Adjusting Screw such that the Torque Bar is parallel with the Displacer Arm (30) when the tip of the Adjusting Screw is touching the bottom of the Torque Bar.

Remove the Torque Bar, being careful not to disturb the position of the Adjusting Bar, and fully tighten the two Capscrews securing the Adjusting Bar to the Pivot Shaft. **DO NOT OVERTIGHTEN.**

Slide the Torque Bar back in place with the hole for the Upper Guide oriented on bottom and in proper position to accept the Upper Guide once the Spring is re-installed. Secure the Torque Bar with the Nyloc Nut, leaving approx. 1/16" clearance between the bottom of the nut and the Torque Bar. **IMPORTANT! The Torque Bar must be able to move freely on the Pivot Arm. Tightening the Nyloc Nut too much will inhibit this free travel.**

Slide the Flapper Bar back onto the Stud and secure with the other Nyloc Nut. **IMPORTANT!** Do not over-tighten this nut, as the Flapper Bar must be able to move freely on the Stud.

Re-install the Stud and Adjusting Wheel. Install the Spring and Upper Guide, engaging the extrusion on the Upper Guide into its mating hole on the bottom of the Torque Bar.

Pilot Removal/Replacement

WARNING!

Prior to removing Pilot system must be isolated from pressure. Failure to do so may result in personal injury, environmental spill concerns and/or damage to equipment.

The Pilot (4) is held in place by the Pilot Clamp (36) and four Capscrews (35). Remove the Capscrews, Pilot Clamp and Pilot from the Control Box. Inspect condition of Gasket (34) and replace if necessary.

Re-install the Pilot, assuring that the Gasket is seated properly with port holes aligned with ports in Pilot and Control Box.

Body Disassembly

Remove the Body from the Control Box as described in the **General Disassembly** section.

CAUTION! If the Shaft Retainers (9) are removed, O-Rings (7 and 10) and Back-up Rings (8) MUST BE REPLACED.

Remove the two Shaft Retainers (9) utilizing a 1-1/8" wrench. Remove the Pivot Shaft (6). Remove the Pivot Shaft O-Rings (7), Back-up Rings (8) and Shaft Retainer O-Rings (10) and discard.

The Bearings (42) and Tolerance Rings (43) need not be removed from the Shaft Retainers unless they are damaged and must be replaced.

Body Reassembly

Lightly lubricate new O-Rings and Back-Up Rings with oil. Install Pivot Shaft Back-Up Ring into Shaft Retainers first, with O-Ring next. **IMPORTANT! The Back-Up Ring MUST be outboard of the O-Ring, as illustrated.**

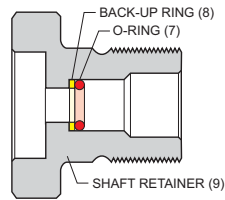

Thread the **outboard** Shaft Retainer into the Body.

Insert the Pivot Shaft into the Body from the inboard side, seating it firmly into the Bearing in the Shaft Retainer on the **outboard** side

Re-install the remaining Shaft Retainer over the Pivot Shaft and threaded into the **inboard** side of the Body. Tighten both Shaft Retainers firmly.

Re-attach the assembled Body to the Control Box as described in the **General Reassembly** section.

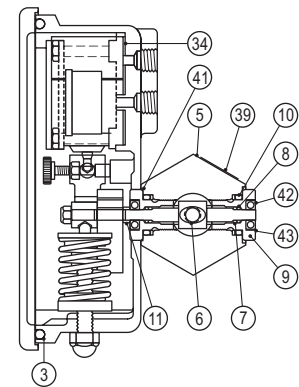
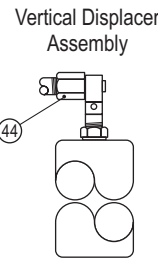
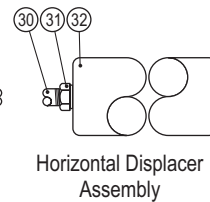
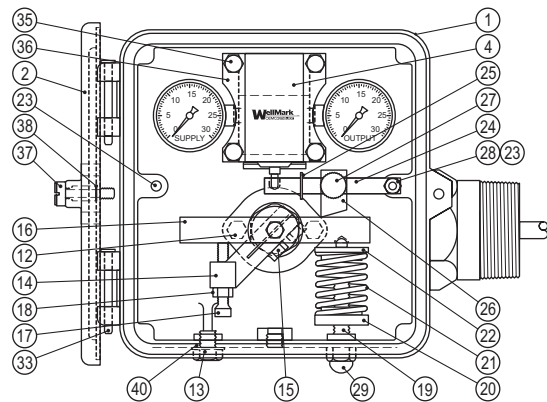

Parts List

Item	Description	Qty.	Part Number
1	CONTROL BOX, Die Cast Aluminum	1	05012-4841
2	COVER, Die Cast Aluminum	1	05012-4834
3	BOX SEAL, Neoprene	1	06000-5097
4	SNAP PILOT ASSY., Aluminum & SS	1	06500-5304
4	THROTTLE PILOT ASSY., Aluminum & SS	1	06500-5387
5	BODY, CS	1	05011-4560
6	PIVOT SHAFT, SS	1	05011-4511
7	O-RING, Viton®	2	05000-0769
8	BACK-UP RING, Teflon®	2	06000-1179
9	SHAFT RETAINER, SS	2	05012-9389
10	O-RING, Viton®	2	05000-1155
11	SPACER, SS	1	05011-4495
12	CAPSCREW, SS	2	05000-5578
13	CAPSCREW, SS	1	05000-5453
14	ADJUSTING BAR, Aluminum	1	05011-4438
15	CAPSCREW, SS	2	05000-2526
16	TORQUE BAR, Aluminum	1	05011-4545
17	ADJUSTING SCREW, SS	1	05011-4537
18	JAM NUT, SS	1	05000-2559
19	STUD, SS	1	05011-4552
20	ADJUSTMENT WHEEL, Aluminum	1	05011-4529
21	SPRING, SS	1	06000-4157
22	UPPER GUIDE, Aluminum	1	05011-4479
23	STUD, FLAPPER BAR, SS	2	05012-9371
24	FLAPPER BAR, SS	1	05011-4404

Item	Description	Qty.	Part Number
25	TRU-ARC RING	1	06000-1385
26	FULCRUM, Aluminum	1	05011-4412
27	THUMBSCREW, SS/Plastic	1	06500-5429
28	NYLOC NUT, SS	2	05000-2567
29	ACORN NUT, SS	1	05000-2575
30	DISPLACER ARM - STD., SS	1	06000-1534
30	DISPLACER ARM - VF, SS	1	05011-9296
31	DISPLACER BUSHING, SS	1	06000-5105
32	DISPLACER - STD., PVC	1	05012-3561
33	HINGE PIN, Plated CS	2	06000-7537
34	GASKET, Neoprene	1	06000-4819
35	CAPSCREW, SS	4	05000-5313
36	PILOT CLAMP, SS	1	05012-6325
37	PANEL SCREW, SS	1	06000-1153
38	RETAINER, SS	1	06000-2672
39	SERIAL TAG, Aluminum (not shown)	1	06000-1922
40	THREAD SEAL, Steel/Buna N	1	06000-0395
41	O-RING, Viton®	1	05000-5586
42	BEARING, SS	2	06000-7552
43	TOLERANCE RING, SS	2	06000-7560
44	ADAPTER, VERT. DWN ASSY., SS	1	06500-4350
45	COVER GLASS, Lexan® (not shown)	2	10916
46	COVER GLASS PLATE, SS (not shown)	2	10915
47	COVER GLASS GSKT, Neoprene (not shown)	2	10917
48	SCREW, Plated Steel (not shown)	8	001501P